

"Are machine tools your business?"

**From OEM to End-user, we are the experts in delivering quality machine protection
Value for money solutions for the machine tool and manufacturing industry.**

- **Sub-contract CNC sheet metal work** • **Swarf Conveyors manufactured & re-furbished**
- **Telescopic Guards manufactured & re-furbished** • **Design Service** • **Onsite PM surveys**
- **Complete Machine Systems** • **Bespoke Machine Safety Guarding Systems**

"QUALITY MACHINE PROTECTION"



Telescopic Steel Covers



Swarf Conveyors



Safety Guarding Systems

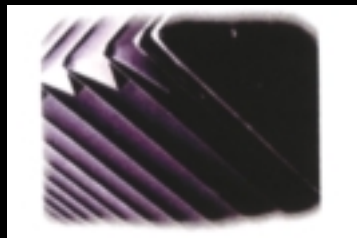

Fabric Bellows



High-Speed Roll-up Covers



Roll-up Covers



Riveted Apron Covers

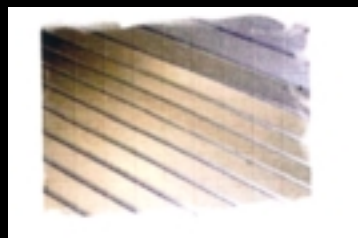

Apron Covers



CNC-Sub Contract Sheet Metal

Units 1&2, Moderna Industrial Estate, Moderna Way, Mytholmroyd, Halifax HX7 5QQ
•Tel: 01422 881881 •E-mail: sales@guard-tech.co.uk •Web: www.guard-tech.co.uk

Head Office

Contact: Scott Gravenor

Phone: 01422 881881

Fax: 01422 884789

Mobile: 07919 380219

E-mail: sales@guard-tech.co.uk

Preston Office

Contact: Rachel Sanderson

Phone: 01772 619308

Fax: 01772 611887

Mobile: 07919 558299

E-mail: sfsmain@aol.com

Telescopic Steel Covers

We cover all makes / types of machine tool irrespective of the original guard manufacturer and have considerable experience on Mazak, Okuma, Nakumuru, Makino, Daewoo and Dorries Scharmann machining and turning centres.

Heavy investment in machinery and personnel training by our partners, under the guidance of highly qualified engineers have allowed us to face the real challenges of high accuracy / high speed machines operating for longer production times.

If you have a guarding problem, contact GUARD-TECH for fast response, quick delivery and your satisfaction guaranteed.

At the same time, we give utmost consideration to the quality / price ratio, ensuring that our customers get the most from their investment.

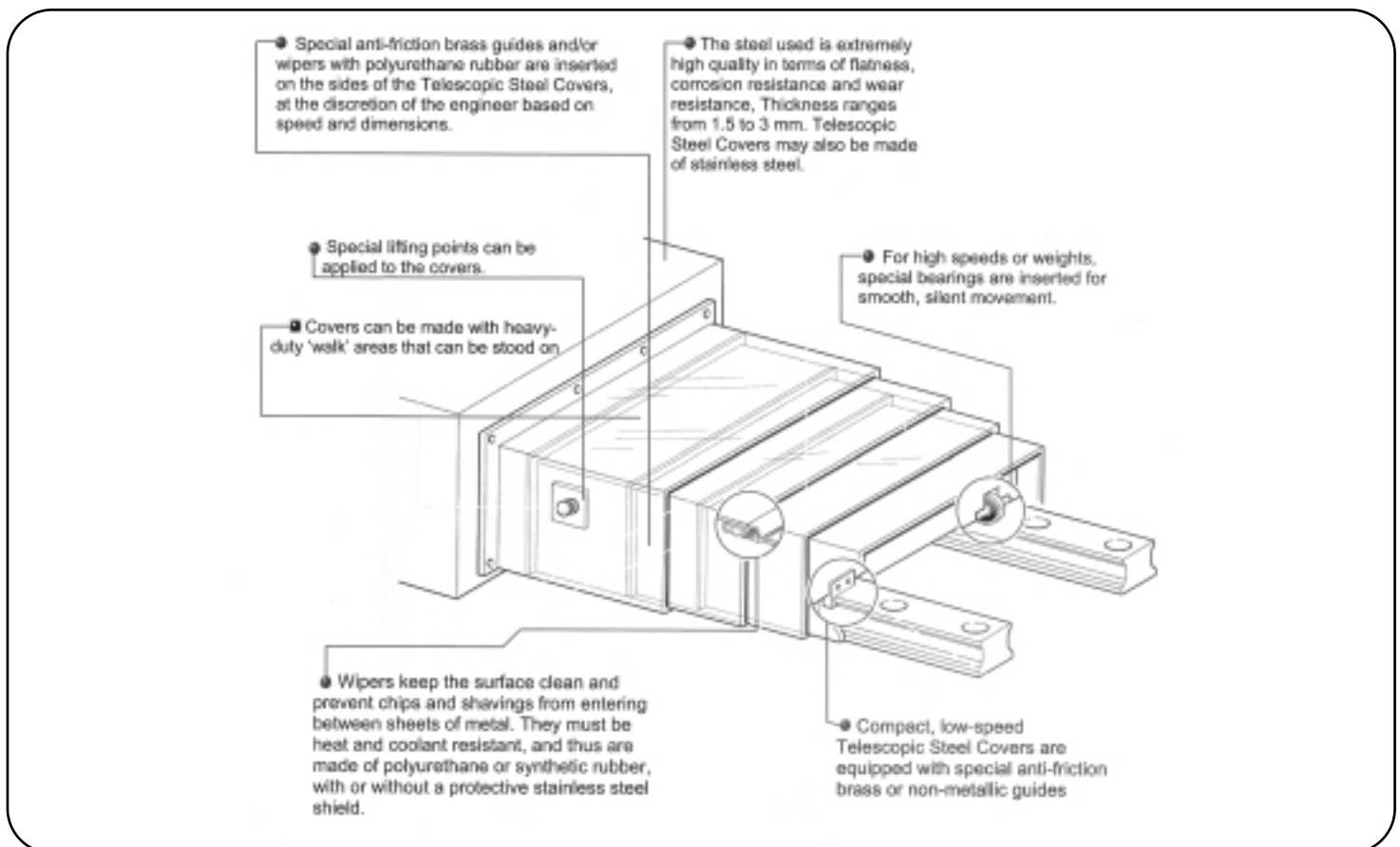

Units 1&2, Moderna Industrial Estate, Moderna Way, Mytholmroyd, Halifax HX7 5QQ

Head Office

Contact: Scott Gravenor

Phone: 01422 881881

Fax: 01422 884789

Mobile: 07919 380219

E-mail: sales@guard-tech.co.uk

Preston Office

Contact: Rachel Sanderson

Phone: 01772 619308

Fax: 01772 611887

Mobile: 07919 558299

E-mail: sfsmain@aol.com

Telescopic Steel Covers

Avoiding exposure to swarf and coolant ingress into sensitive machine areas means having efficient machine covers. Unfortunately, breakdown due to contamination can be all too common. We can provide the solution:

Replacement / Refurbishment Service

- *Full refurbishment service*
- *Fast turnaround*
- *Dented and damaged panels repaired / replaced*
- *Worn shoes, rollers and guides replaced and re-lubricated*
- *Replacement wipers*
- *Covers re-polished and oiled*

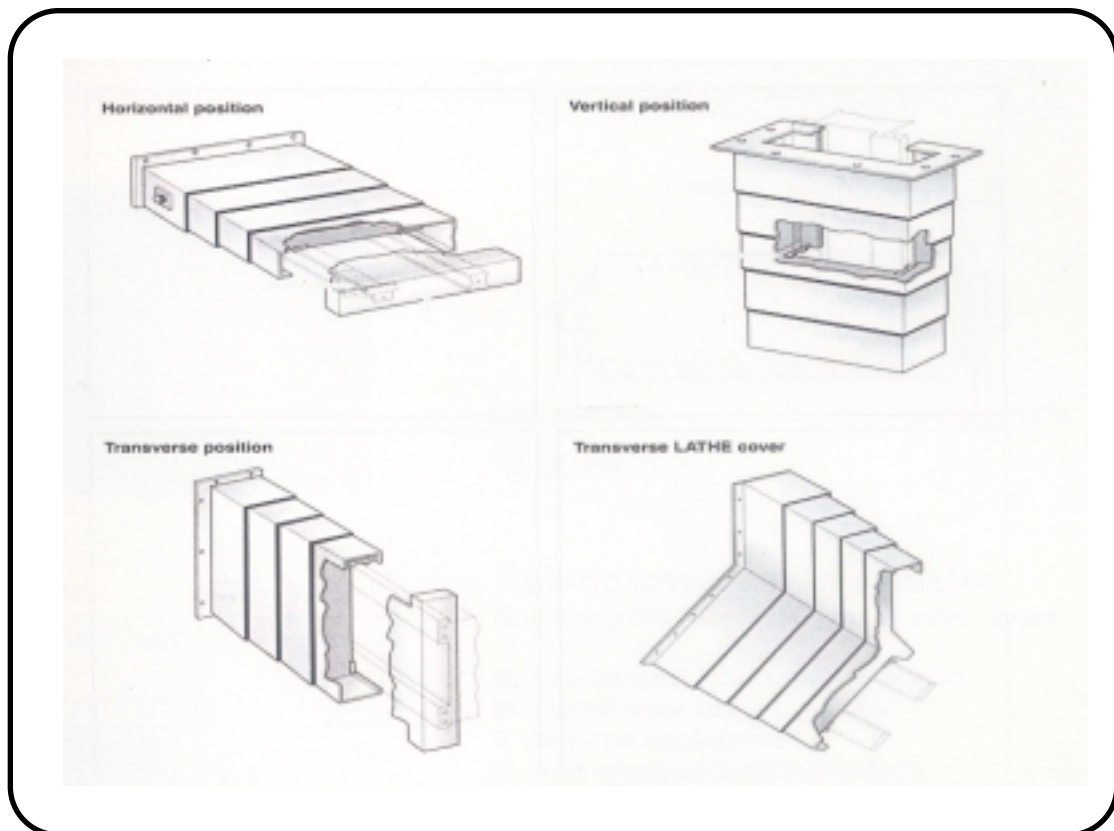

Units 1&2, Moderna Industrial Estate, Moderna Way, Mytholmroyd, Halifax HX7 5QQ

Head Office

Contact: Scott Gravenor

Phone: 01422 881881

Fax: 01422 884789

Mobile: 07919 380219

E-mail: sales@guard-tech.co.uk

Preston Office

Contact: Rachel Sanderson

Phone: 01772 619308

Fax: 01772 611887

Mobile: 07919 558299

E-mail: sfsmain@aol.com



Swarf Conveyor Systems



Outside Discharge Conveyor with swivelling chute for maximum Swarf dispersal.



Full Factory Installation of 17 Conveyors



In-line Conveyors Incorporating Chutes and Walkway System

GUARD-TECH's Swarf Conveyor service is focused on providing a first class product and services at a keenly competitive price with a fast turnaround.

We provide a comprehensive refurbishment service undertaken in our own workshops to badly worn or damaged conveyors to an 'as new' condition.

To complement our refurbished activities we also manufacture new conveyors from CAD design to manufacture and installation (if required) to new or existing designs from single units to full factory swarf management systems.

Many of our customers are 'Blue Chip' engineering companies operating within Aerospace, Offshore Oil, Defence and Automotive industries where quality, timescale and price must all be satisfied on every occasion to maintain their business.

We cover all make / type of machine tool irrespective of the original conveyor manufacture and have considerable experience on Salt belt, Scraper and Magnetic types.

If you have a problematic swarf conveyor or looking for a new or replacement unit contact GUARD-TECH for a fast response to resolve your problem.

Units 1&2, Moderna Industrial Estate, Moderna Way, Mytholmroyd, Halifax HX7 5QQ

Head Office

Contact: Scott Gravenor

Phone: 01422 881881

Fax: 01422 884789

Mobile: 07919 380219

E-mail: sales@guard-tech.co.uk

Preston Office

Contact: Rachel Sanderson

Phone: 01772 619308

Fax: 01772 611887

Mobile: 07919 558299

E-mail: sfsmain@aol.com

Custom Built Safety Enclosures & Machine Safety Guards to HSE Requirements



MACHINE GUARDING

At GUARD-TECH, we strive to engineer, develop and manufacture guarding systems to protect your workforce from accidents, dust, fumes and noise while enhancing your equipment and appearance.

Machine guarding is one of our specialities. We have successfully designed, manufactured and installed guarding that is being used in many of today's Blue Chip companies. At GUARD-TECH we offer a bespoke design service that is worked closely with our customer to achieve total satisfaction on the end product.

Prior to manufacture on any of our guarding products a full set of CAD drawings are supplied for customer approval and satisfaction.

We will manufacture to your specification or engineer a solution for you.

For any immediate or future requirements you may have, we would welcome the opportunity to quote for your work.

Units 1&2, Moderna Industrial Estate, Moderna Way, Mytholmroyd, Halifax HX7 5QQ

Head Office

Contact: Scott Gravenor

Phone: 01422 881881

Fax: 01422 884789

Mobile: 07919 380219

E-mail: sales@guard-tech.co.uk

Preston Office

Contact: Rachel Sanderson

Phone: 01772 619308

Fax: 01772 611887

Mobile: 07919 558299

E-mail: sfsmain@aol.com

Fabric Bellows

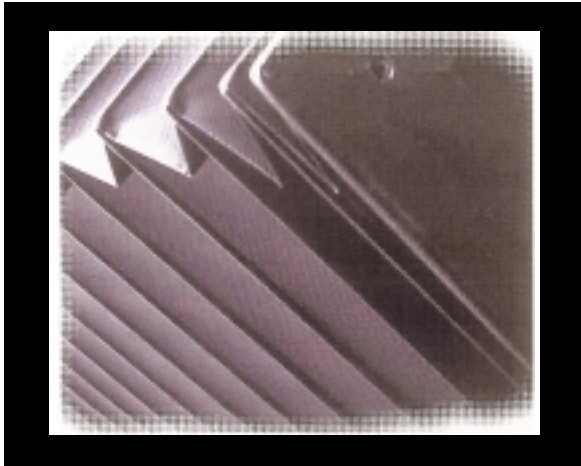

Seamless, flexible covers in a wide variety of materials to provide excellent protection and a long-term working life.

These covers can be custom made to any shape with a range of end fittings. The bellows can include threaded inserts, holes to customers drawings and strong hold Velcro strips for ease of removal / inspection.



Internal supports in PVC - choice of 3 thicknesses

Materials

Thermic welded bellows can be made in various materials (see enclosed materials list) suitable for all applications. Designed to meet every machine environment - EDM, Lasers, Lathes, Millers, Grinders, CMM etc....

Bellows with steel flanges

Extra protection in harsh environments or for when chips are particularly sharp or hot. The steel flanges provide extra protection and enhance the appearance of the machine.

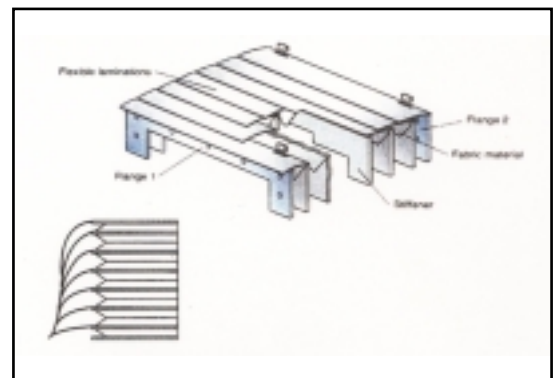

Units 1&2, Moderna Industrial Estate, Moderna Way, Mytholmroyd, Halifax HX7 5QQ

Head Office

Contact: Scott Gravenor

Phone: 01422 881881

Fax: 01422 884789

Mobile: 07919 380219

E-mail: sales@guard-tech.co.uk

Preston Office

Contact: Rachel Sanderson

Phone: 01772 619308

Fax: 01772 611887

Mobile: 07919 558299

E-mail: sfsmain@aol.com

Moulded Rubber Bellows



One piece expanding bellows to protect rams, screws, joints and other mechanisms.

Custom moulded in synthetic rubber (nitrile), natural rubber, silicone or neoprene to almost any shape.

The information we require is shown below:

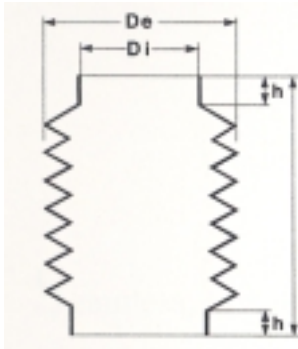

De = Outside Diameter

Lmax = Maximum Open Length

Lmin = Minimum Closed Length

H = Height of Collars (unless other fixing is required)

Anti-Vibration Mounts

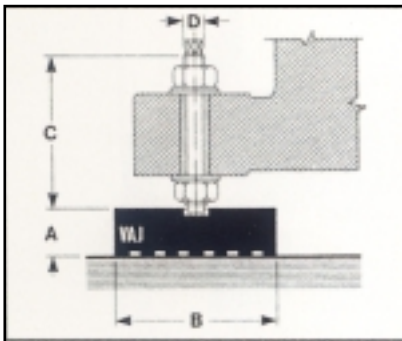

A range of anti-vibration machine mounts made from vulcanised synthetic rubber on a large steel plate with high strength steel levelling screws and nuts. Excellent value for money and very easy to use.

HEAVY SQUARE TYPE - WITH LEVELLING DEVICE

Type	A	B	C	D	Load (kg)
P60	35	60 x 60	120	M12	240
P80	35	80 x 80	120	M12	450
P100	35	100 x 100	130	M16	600
P120	35	120 x 120	130	M16	1000
P140	35	140 x 140	170	M20	1500
P160	35	160 x 160	170	M20	2500

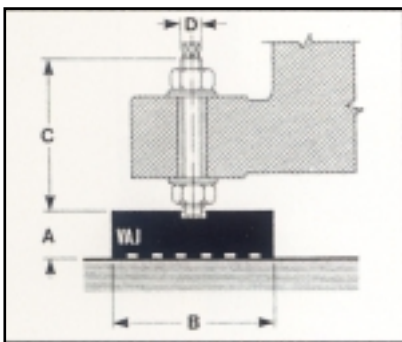

LIGHT TYPE - WITHOUT LEVELLING DEVICES

Type	A	B	C	D	Load (kg)
L50	16	50	37	M10	78
L85	16	85	37	M10	196
L120	16	120	37	M10	390

Units 1&2, Moderna Industrial Estate, Moderna Way, Mytholmroyd, Halifax HX7 5QQ

Head Office

Contact: Scott Gravenor

Phone: 01422 881881

Fax: 01422 884789

Mobile: 07919 380219

E-mail: sales@guard-tech.co.uk

Preston Office

Contact: Rachel Sanderson

Phone: 01772 619308

Fax: 01772 611887

Mobile: 07919 558299

E-mail: sfsmain@aol.com

Sure Spring Mechanism

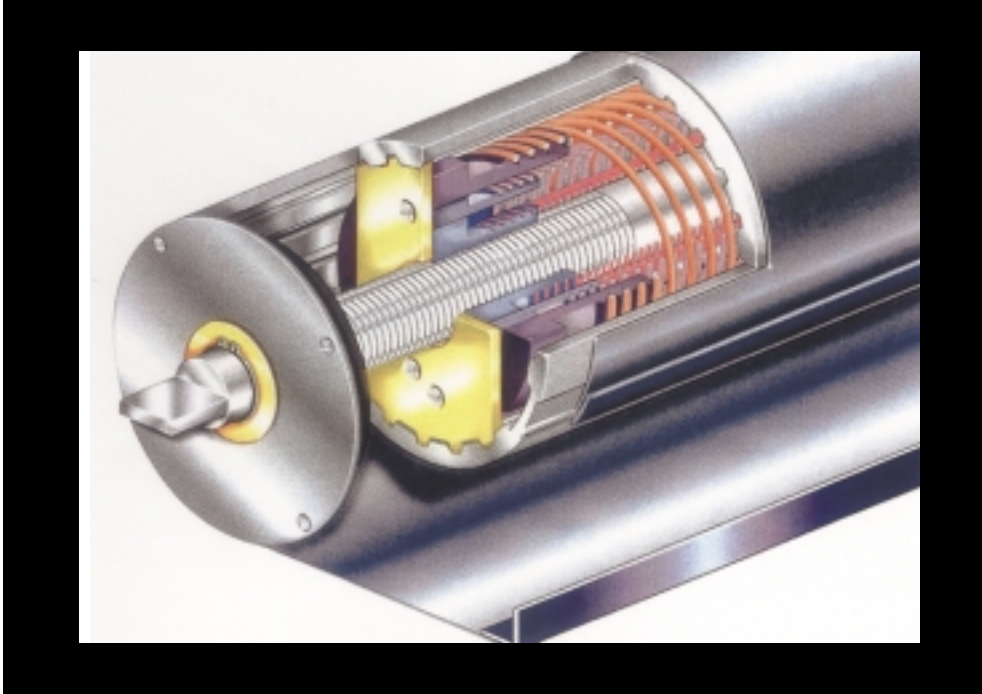

The P.E.I. Patented design known as SURE-SPRING[®] represent the most advanced level of technical innovation in the field of roll-up covers.

The spring mechanism design takes into account the intrinsic defects in other rollers available on the market, and overcomes them by means of a radical new design of the spring mechanism.

The second major innovation consists of the mechanical system, to fasten the band to the tube.

No adhesives are needed for this roll-up cover!!

In addition to those of standard P.E.I. roll-up covers, P.E.I. SURE-SPRING[®] roll-up covers offer the following advantages:

- Advancement speed of up to 150 m/min.*
- Acceleration of upto 2G.*
- 2,000,000 movements guaranteed.*

Units 1&2, Moderna Industrial Estate, Moderna Way, Mytholmroyd, Halifax HX7 5QQ

Head Office

Contact: Scott Gravenor

Phone: 01422 881881

Fax: 01422 884789

Mobile: 07919 380219

E-mail: sales@guard-tech.co.uk

Preston Office

Contact: Rachel Sanderson

Phone: 01772 619308

Fax: 01772 611887

Mobile: 07919 558299

E-mail: sfsmain@aol.com



Roll-up Covers

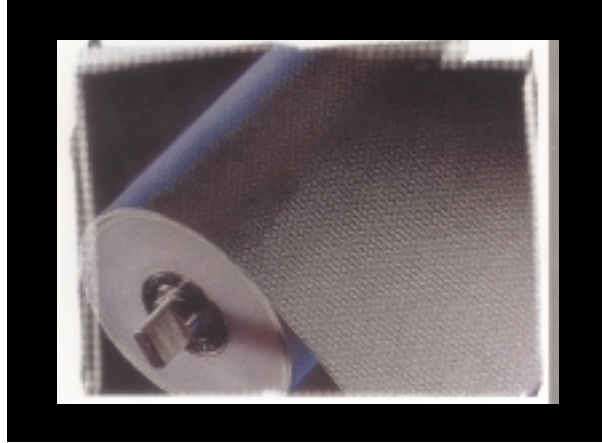

Roll-up covers are normally supplied with a patented multiple spring system. The band is available in a variety of materials including stainless steel (see materials list).

These covers offer:

- *Reliability*
- *Extremely High Speeds*
- *Resistance to Extreme Temperatures*
- *Compact Size*
- *Easy Installation*
- *Constant Tensioning*
- *Variety of Fixing Arrangements*
- *1,000,000 Movements Guaranteed*

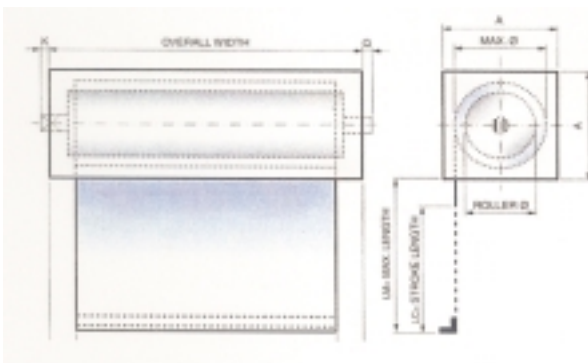
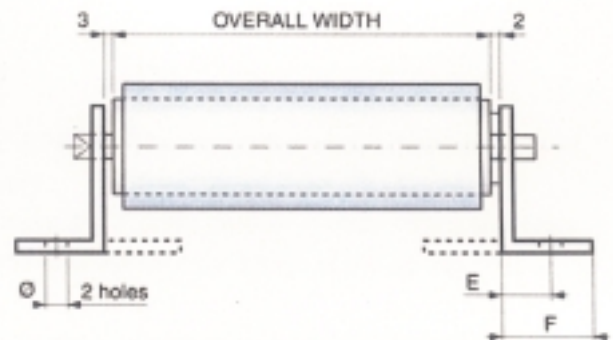

*Roll-Up Covers with Canister
Enclosing the roller offer many advantages:*

- *Protects roller from accidental impact*
- *Integral wiper keeps band clean*
- *Attractive appearance*
- *Wide variety of fastening systems*
- *Enhanced machine appearance*
- *Materials: Aluminium, Steel, Stainless Steel*
- *1,000,000 movements guaranteed*

Units 1&2, Moderna Industrial Estate, Moderna Way, Mytholmroyd, Halifax HX7 5QQ

Head Office

Contact: Scott Gravenor

Phone: 01422 881881

Fax: 01422 884789

Mobile: 07919 380219

E-mail: sales@guard-tech.co.uk

Preston Office

Contact: Rachel Sanderson

Phone: 01772 619308

Fax: 01772 611887

Mobile: 07919 558299

E-mail: sfsmain@aol.com

Apron Covers

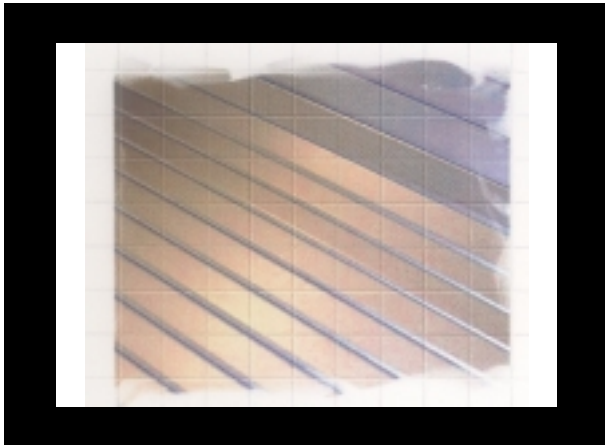

A range of apron covers for protecting machine tools. Available either on a roller or as a simple curtain length (to your requirements) with as variety of fixing profiles, these aprons offer excellent value for money.

Can be made to suit any machine size (up to 6000mm width)

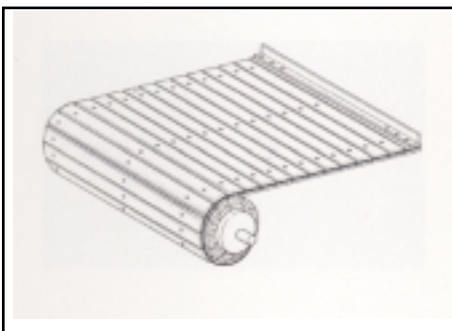
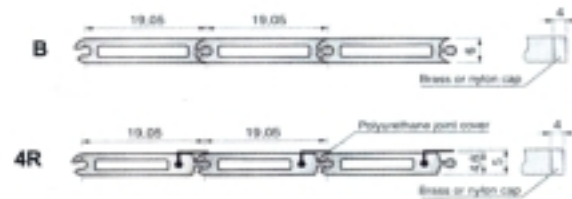
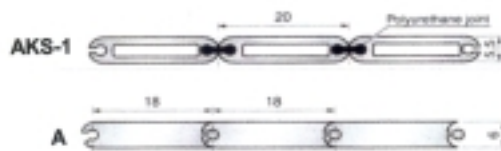

Heavy duty covers with upper and lower elements of in aluminium, steel or brass.

As with flexible aluminium covers above, these aprons can be supplied with or without rollers and also with a choice of end fittings.

Please call for detailed information.

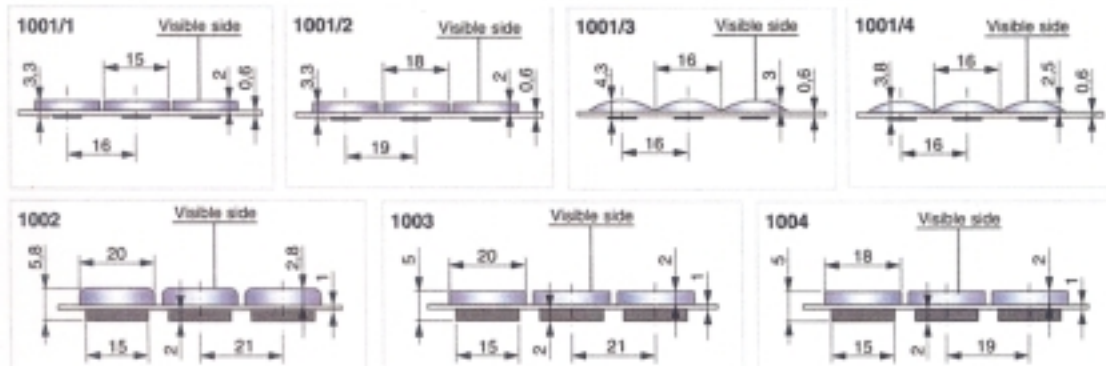

Units 1&2, Moderna Industrial Estate, Moderna Way, Mytholmroyd, Halifax HX7 5QQ

Head Office

Contact: Scott Gravenor

Phone: 01422 881881

Fax: 01422 884789

Mobile: 07919 380219

E-mail: sales@guard-tech.co.uk

Preston Office

Contact: Rachel Sanderson

Phone: 01772 619308

Fax: 01772 611887

Mobile: 07919 558299

E-mail: sfsmain@aol.com

CNC Sheet Metal Work



“Think Quality - Think Value”

When you think of quality, value and service in the CNC metal fabrication industry, the name GUARD-TECH should come to mind.

GUARD-TECH offers a diverse range of custom and production CNC metal fabrications.

We have gained vast experience with Mild Steel, Stainless Steel and Aluminium, from metal forming, bending, punching prototypes, production, welding and finishing services that allow for a ‘Single Source Solution’.

We pride ourselves on providing you with high value-to-cost metal parts.....On time.

We recognise that every customer has unique requirements, but whatever the requirements, our customers agree- they want quality and service.

GUARD-TECH does it’s best to meet those needs with a powerful blend of technical experience and superior quality.

For any immediate or future requirements you may have, we would welcome the opportunity to work for you.

Units 1&2, Moderna Industrial Estate, Moderna Way, Mytholmroyd, Halifax HX7 5QQ

Head Office

Contact: Scott Gravenor

Phone: 01422 881881

Fax: 01422 884789

Mobile: 07919 380219

E-mail: sales@guard-tech.co.uk

Preston Office

Contact: Rachel Sanderson

Phone: 01772 619308

Fax: 01772 611887

Mobile: 07919 558299

E-mail: sfsmain@aol.com

www.guard-tech.co.uk